

BIZERBA

■ ... closer to your business

Bizerba GSP series slicers are now certified to the new NSF ANSI 8 2010 standard.

Safety is our top-priority ...

... GSP HD series – automatic safety slicer ...

Bizerba is the first manufacturer to achieve this world-class standard!

GSP HD

- Energy Savings – average of 50% savings over competitors' models
- Widest product carriage for increased capacity
- One piece anodized aluminum construction
- Fast and easy to clean, fewer seams, large radii
- Improved sealing against water and debris
- Largest and easiest to use remnant holder in the industry
- Unique design allows for the smallest end pieces, increased product yield
- The ability to adjust both the speed and the stroke of the carriage "on-the-fly" will speed up your operation
- The ergonomic design of the Bizerba GSP HD series sets the standard for safety, yield, hygiene, durability, and lowest overall cost of ownership
- Safety features: Shut off in slice thickness knob, adjustable blade shut off and start at zero (safe-only)
- Improved liquid and debris diversion from all control surfaces
- Largest thumb guard for maximum protection
- Zero blade exposure during the cleaning process
- Remote sharpener is dishwasher safe for improved safety and hygiene
- One piece carriage with seamless thumb guard for highest hygiene standards
- Servo assist function reduces operator fatigue during manual mode
- Top quality gravity feed slicer with low-profile carriage for heavy product



Best blade in the industry

The unique design of our blade produces clean and consistent slices. The hardness results in a long lasting sharp edge. The life of the blade is dramatically longer than the competition. Our standard blade is the hardest, thinnest, largest, straightest blade in the industry.

- 13" diameter, chromium coated hard alloy
- 60-62 Rockwell hardness at the edge

BIZERBA

■ ... closer to your business

1-phase AC current

- 120 V, specialised data available on request
- 60 Hz
- Frequency of nominal current 2.6 A
- Power consumption 0.240 kW

Blade diameter

- 13" (330 mm)

Blade speed

- 255 r.p.m.

Max. produce size

- Round: 7.95" (202 mm)
height: 4.96" (126 mm)
width: 11.42" (290 mm)

Strokes per minute

- Full: 30-40-50
mid: 35-48-58
short: 60-68-75

Slice thickness

- 0-0.94" (0-24 mm), infinitely variable

Installation area

- (L x W) 20.94" x 17.48" (532 x 444 mm)

External dimensions (carriage inclined at 25°)

- (L x W x H) 28.5" x 22.48" x 24.67"
(724 x 571 x 627 mm)

Operating area

- (L x W) 31.73" x 35.39" (806 x 899 mm)

Protection type

- IP 33

Weight of machine

- 122 lbs, 55 kg

Additional equipment

- Vegetable chute
- Product fences
- PW scale 120 V/60 Hz, 540 W



Carriage inclined at 25°

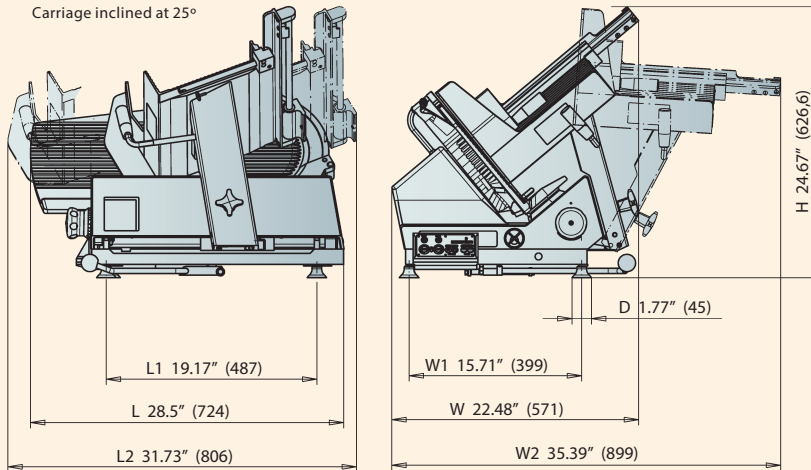

Warranty

The GSP HD Safety Slicer carries a one-year, on-site parts and labor warranty against any flaws in materials and workmanship. This period begins with the date of purchase and, provided the unit is used properly in accordance with our instructions, is in full effect for one year from that date. Any work to be performed under this warranty must be performed between the hours of 8:00 a.m. and 4:30 p.m. local time, Monday to Friday. Bizerba will not pay over-time charges for work performed other than during normal business hours. Accessories have a 30-day replacement or repair warranty for the period beginning on the date of purchase. Damages incurred in transit or from installation error, accident, alteration or misuse are not covered. Transit damages should be reported to the carrier immediately. Bizerba shall not be liable for any consequential, compensatory, incidental, or special damages. All warranty work must be performed by a factory authorized Bizerba Representative.

III/231us © 1st edition. Subject to change without notice. 031140 BA